

OREC™ Type G Ozonators: Description



The OREC™ Type G Ozonators are designed to interface with a wide range of industrial applications. The ultra-compact, fiberglass reinforced cabinet makes the Type G suitable for demanding environments... aquaculture and agriculture, cooling tower and wastewater treatment, as well as many other commercial applications.

The Type G Ozonators incorporate an air-cooled titanium and ceramic reactor cell design with a high frequency variable controlled power supply. The G Type Ozone Generators offer a full range of output performance, from 3 g/hr to more than 60 g/hr... all in the same lightweight, sturdy, fiberglass reinforced, wall mountable enclosure.

The Type G Ozonator is among the most energy efficient in the industry! Their high concentration ozone output and low power consumption coupled with variable control; feed gas control; reactor back pressure gauge; power supply feed back output; and LED ozone output indicator.

Type G ozonators can be controlled manually or remotely using a 0–10 VDC or 4–20 mA signal from an ozone analyzer, ozone process controller, ORP (oxidation reduction potential) controller or other control signal allows tremendous flexibility.

The OREC™ Type G Ozonators feature an integrated automatic cooling fan which keeps moisture out, even in cool or humid outdoor applications. The modular design combines the power supply with a titanium and ceramic reactor cell for improved field serviceability, providing years of trouble-free operation.

OREC™ Type G Ozonators: Technology

All OREC™ Type G Ozonators feature corona discharge ozone generators that produce comparatively high concentrations of ozone for the duration of a long, virtually service-free life.

The titanium-ceramic, *ultra-narrow-gap*, corona discharge reactor cell is energized by a solid state power supply, providing proportional control of ozone output. The *ultra-narrow-gap* corona discharge reactor cell equates to energy efficient and responsive ozone generation.

OREC™ has combined *ultra-narrow-gap* technology with engineered, high frequency, pulse modulated power supplies and instantaneous amplitude modulated variable control to maximize ozone output efficiency and provide precise ozone concentrations.



The Ozonators are constructed of ozone resistant components such as titanium electrodes, ceramic dielectrics, 316 stainless steel fittings, and Teflon® tubing to ensure reliability and maintenance-free performance. The Ozonators are air-cooled, employing large aluminum heat sinks and high volume fans for maximum heat transfer and optimal cooling, an important factor in improving ozone output.

Each OREC™ Ozonator is tested in a full range of operational conditions for ozone output and performance. OREC™ is unique, on a global basis, in having received *Direct Traceability* from the National Institute of Standards and Technology (NIST) and is ISO/IEC 17025 (A2LA) certified for ozone calibration!

OREC™ Type G Ozonators: Features

- Reinforced fiberglass enclosure;
- Stainless steel hardware;
- Air cooled ceramic and titanium dual action reactor cell;
- Over temperature safety switch;
- Integrated PSA air dryer technology (Model G11 only);
- Feed gas flow switch.

OREC™ Type G Ozonators: Options

- Oxygen Concentrator;
- Oxygen Generator (feed gas supply);
- Air Dryer;
- PID Controller;
- Ozone Monitor;
- Ozone Gas Detector.

OREC™ Type G Ozonators: Controls

- Variable output control: 0 – 100%;
- On/Off illuminated circuit breaker;
- Feed gas flow control: 0 – 30 SCFH;
- Power feed back reference meter 0 – 15 VDC;
- Reactor pressure gauge 0 – 15 PSI;
- LED ozone indicator.

OREC™ Type G Ozonators: Specifications

Model:	G11	G21	G22	G23	G24
Ozone Production: (10 SCFH O ₂ feed gas supply)	13 g/hr 0.7 lb/day	19 g/hr 1.0 lb/day			
Ozone Production: (20 SCFH O ₂ feed gas supply)	16 g/hr 0.8 lb/day	24 g/hr 1.3 lb/day	30 g/hr 1.6 lb/day	45 g/hr 2.4 lb/day	50 g/hr 2.6 lb/day
Ozone Production: (30 SCFH O ₂ feed gas supply)			40 g/hr 2.1 lb/day	52 g/hr 2.7 lb/day	
Ozone Production: (40 SCFH O ₂ feed gas supply)					52 g/hr 2.7 lb/day
Ozone Production: (10 SCFH dry air feed gas supply)	3.5 g/hr 0.2 lb/day	4.3 g/hr 0.2 lb/day			
Ozone Production: (15 SCFH dry air feed gas supply)				8.9 g/hr 0.4 lb/day	
Ozone Production: (20 SCFH dry air feed gas supply)	6.0 g/hr 0.3 lb/day	8.3 g/hr 0.4 lb/day	9.1 g/hr 0.5 lb/day	18.0 g/hr 1.0 lb/day	15.0 g/hr 0.8 lb/day
Ozone Production: (40 SCFH dry air feed gas supply)					24.0 g/hr 1.3 lb/day
Oxygen Concentration Oxygen:	3 – 7 percent by weight		3 – 8 percent by weight		
Oxygen Concentration Dry Air:	1 – 2 percent by weight				
Maximum Reactor Pressure:	15 PSI				
Feed Gas Flow Range:	0 – 30 SCFH		0 – 50 SCFH		
Variable Control:	0 – 100%				
Power Consumption:	230 Watts	300 Watts	370 Watts	440 Watts	530 Watts
Air Cooling:	240 CFM				
Power Supply Fuse:	8 Ampere				
On/Off Circuit Breaker:	15 Ampere				
Compressed Air Inlet Connector:	0.25 inch female pipe thread				
Ozone Outlet Connector:	0.25 inch tube				
Power Requirement:	115/230 VAC · 50/60 Hz · 1 Phase				
Dimensions (H x W x D):	18 x 16 x 11 in. (457.2 x 406.4 x 279.4 mm)				
Weight:	44 lbs. (20 kg)	49 lbs. (22 kg)	51 lbs. (23 kg)	53 lbs. (24 kg)	55 lbs. (25 kg)

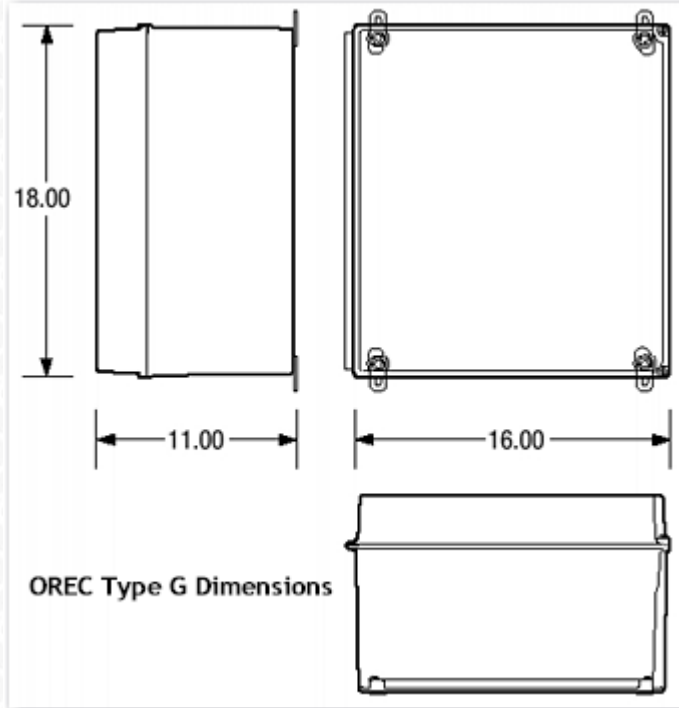

NIST Direct Traceability & ISO/IEC 17025 Accredited Calibration Laboratory

NIST

National Institute of Standards & Technology

Direct (Primary) Traceability

[NIST Report 839.03-03-155](#)

[NIST Report 839.03-05-168](#)



American Association for Laboratory Accreditation

[Instrument Calibration Certificate 1424.01](#)

[Mechanical Testing Certificate 1424.02](#)

[| QUICKQUOTE](#) | [| TECHINFO](#) | [| ADOBE® DOWNLOAD](#) | [| NO VERSIÓN ESPAÑOLA](#) | [| BACK](#) | [| HOME](#) |

© 2006 [Ozone Research Equipment Company](#) • All Rights Reserved • Published: June 20, 2006

221 Beaver Street • Akron, Ohio 44304 • U.S.A.

Telephone: 800.742.8535 • Facsimile: 800.229.9329